

NEPTUNE

INFINITI

All-Weather Long-Range Gyro Stabilized PTZ Camera

The Neptune PTZ is designed for mobile and marine applications with 2-axis gyro stabilization and various EO/IR payload configurations. Numerous visible zoom lens options up to 510mm, and sensor resolutions available from Full-HD up to 8MP/4K make the Neptune a high performance day camera. When paired with up to 2000m of ZLID illumination or up to a 235mm cooled thermal imaging camera, the Neptune system offers remarkable nighttime surveillance performance as well. All of these sensors are integrated into a rugged IP67 weatherproof housing constructed of strengthened aluminum. The Neptune is built to withstand some of the harshest climates, making it ideal for perimeter security, homeland defense, and coastal protection.

Key Features:

- › Long-Range Day/Night PTZ Camera System
- › 2MP, 4MP or 8MP High-Resolution CMOS Sensor
- › HD Lens with 30X, 36X, 49X or 88X Optical Zoom
- › Optical Field of View Options ranging from 75° to 1.18°
- › ZLID™ for up to 2km Night Vision in Complete Darkness
- › Thermal Imaging for Long-Range Detection up to 25km*
- › Optional 15-235mm 15X 10µm X-Hot Cooled Thermal
- › Designed for Operation in -30°C to +60°C with IP67 Housing
- › High Resolution Pan/Tilt with 2-Axis Gyro Stabilization
- › Control via RS485/Pelco-D or Octagon Bridge/API Commands
- › Optional Integrated Optical Fog Filter

Optional Features:

- › GPS & 4G Cellular
- › Laser Rangefinder
- › Marine Joystick
- › Slew-to-Cue via NMEA 0183
- › Military Vibration/Shock Mount
- › Wide-Angle 4K Spotter Camera



*The Neptune's default color is white. Custom colors (such as desert sand pictured here) must be specified at time of order.

4.7mm-141

30X 4MP

6mm-218

36X 4MP

6mm-180

30X 8MP

6mm-218

36X 8MP

5.8mm-510

88X 2MP

5.6mm-272

49X 8MP

35mm

LWIR

55mm

LWIR

26mm-75mm

LWIR

15mm-235

MWIR

500m
ZLID™

1km
ZLID™

2km
ZLID™



2-Axis Gyro Stabilization



Optional LRF



Waterproof with Military Connectors

Multiple Zoom Lens Options up to 272mm

Optional IR Illumination up to 2km

Optional Thermal up to 275mm Zoom

View the Neptune on our website:



THE NEPTUNE'S Visible/NIR HD Zoom Camera

VIS/NIR Optical Camera

Infiniti's VIS/NIR zoom cameras utilize high-end CMOS sensors to offer excellent spectral sensitivity in the visible and near-infrared wavelengths of light to provide high-quality images optimized for long-range surveillance. They are designed to provide industry-leading performance and quality, with image resolutions ranging from 2MP (1080p HD) to 8MP (4K UHD).



Continuous Zoom Lens Options

The Neptune's precision engineered IR-corrected continuous zoom lens options offer a range of focal lengths with 30X up to 88X optical zoom and integrated rapid autofocus to allow for long-range surveillance of targets without operator intervention or wide angle situational awareness.

Neptune shown here with optional vibration mount.

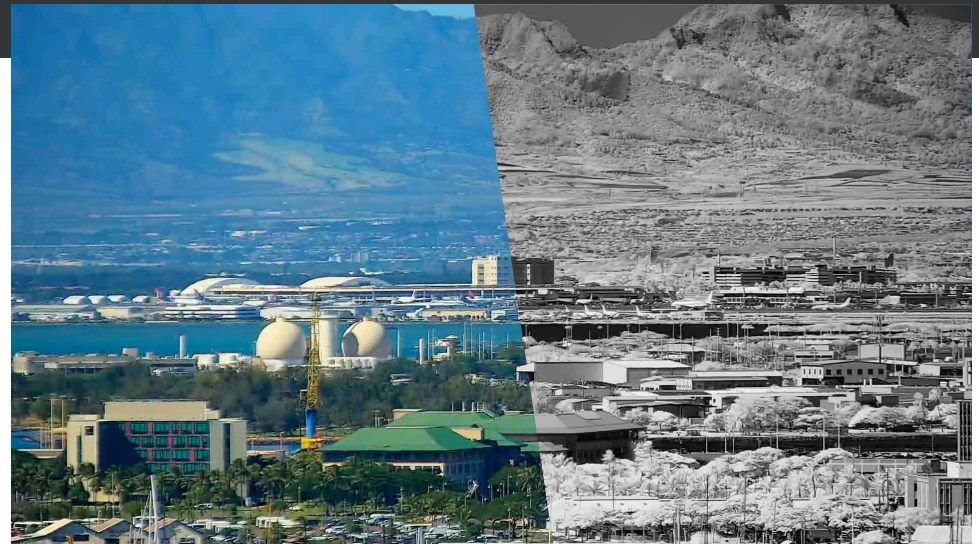

Standard Color Visible Image
(Optical Fog Filter Disabled)

NIR Image
(Optical Fog Filter Enabled)

Optical Fog Filter (NIR Only Mode)

While all of our sensors offer a nighttime NIR+visible mode for optimized sensitivity in low light, the cameras equipped with our NIR bandpass filter (also referred to as a "fog filter") allow users to isolate the NIR (near-infrared) wavelength of light during the day for clearer long-range daytime imaging.

Long-range imaging needs to see through large amounts of atmosphere which often contains particulates like smoke, haze/fog, and other atmospheric distortions. Cutting out the visible wavelength and isolating the NIR can mitigate the effects of smoke, haze and light fog, producing an image with better contrast and less distortion. Our optical fog filter lenses incorporate a motorized filter that is used with the camera's monochrome mode and de-haze image processing to see through smoke, smog and haze; it is available on many of our visible camera modules.

THE NEPTUNE'S ZLID™ & Thermal Technologies



ZLID Image



Thermal Image

See in the Dark with ZLID™

IR illumination allows for detailed video when there isn't enough natural light, however common IR LED illuminators have very limited ranges. For long ranges, a laser is needed. Infiniti's ZLID (Zoom Laser IR Diode) technology synchronizes the IR intensity and area illumination with the zoom lens for outstanding active IR performance, eliminating over-exposure, washout, and hot-spots for clear images in complete darkness. The Neptune can also be customized with white light or military grade 940nm "stealth" ZLID illumination that eliminates the red glow typically present with IR illumination, for covert surveillance and reconnaissance.

See Further with Thermal

An optional thermal imager lets you see further than any other night vision technology. Thermal imaging uses heat to see objects, and since humans, animals, and vehicles are hot in contrast to most backgrounds, they become much easier to spot in a scene. Thermal images are also unaffected by bright light and have the ability to see through atmospheric obstructions such as smoke, dust, and light fog. This makes it an ideal technology for many applications, including surveillance and security, search and rescue, fire, marine and land navigation, wide area situational assessment and much more.

12µm VOx Thermal Imager

The Neptune's LWIR sensor options use a cutting-edge 12µm VOx uncooled sensor, giving the camera a narrower field of view without changing the lens. The smaller 12µm pixel pitch achieves a 40% further range than 17µm sensors or 200% further range than older 25µm sensors. The no-maintenance VOx design is self healing and resistant to solar damage.

235mm MWIR Cooled Thermal

The Neptune's longest range thermal option is a 10µm X-Hot cooled thermal imager with a 15-235mm 15X zoom lens. The smaller 10µm pixel pitch boasts 50% further range than 15µm sensors, making the 235mm lens equivalent to a 350mm lens with detection distances of up to 25km and a 24.1°-1.56° Horizontal FOV.

Human DRI:

55mm Ge lens
 ■ 2,613m
 ■ 871m
 ■ 435m

75mm Ge lens
 ■ 2,969m
 ■ 990m
 ■ 495m

275mm MWIR
 ■ 11,163m
 ■ 3,721m
 ■ 1,860m

Vehicle DRI:

55mm Ge lens
 ■ 6,050m
 ■ 2,017m
 ■ 1,008m

75mm Ge lens
 ■ 6,875m
 ■ 2,292m
 ■ 1,146m

235mm MWIR
 ■ 25,850m
 ■ 8,617m
 ■ 4,308m

■ **DETECTION***
 ■ **RECOGNITION***
 ■ **IDENTIFICATION***

*DRI detection ratings are based on industry-wide standards (Johnson's Criteria) that can be misleading if not properly understood. For more information, please see our whitepaper about understanding DRI measurements at: www.infinitioptics.com/dri

Visible Camera Options

		8M-49X	88X	8M-36X	4M-49X	8M-30X	4M-36X	4M-30X	36X
Simulated FOV @ 1km									
Pixels Per Meter @ 1km		136ppm	128ppm	109ppm	93ppm	90ppm	75ppm	72ppm	58ppm
DORI	D: 25ppm	5,440m Detection	5,100m Detection	4,360m Detection	3,721m Detection	3,600m Detection	2,982m Detection	2,873m Detection	2,325m Detection
	O: 62ppm	2,194m Observation	2,056m Observation	1,758m Observation	1,500m Observation	1,452m Observation	1,202m Observation	1,158m Observation	938m Observation
	R: 125ppm	1,088m Recognition	1,020m Recognition	872m Recognition	744m Recognition	720m Recognition	596m Recognition	575m Recognition	465m Recognition
	I: 250ppm	544m Identification	510m Identification	436m Identification	372m Identification	360m Identification	298m Identification	287m Identification	233m Identification
Output Resolution		4K @ 30fps (3840x2160)	2MP/1080p @ 30fps (1920x1080)	8MP/4K @ 30fps (3840x2160)	4MP @ 30fps (2688x1520)	8MP/4K @ 30fps (3840x2160)	4MP @ 60fps (2688x1520)	4MP @ 30fps (2688x1520)	2MP/1080p @ 60fps (1920x1080)
Image Sensor		8.4 Megapixel 1/1.8" W CMOS	8.4 Megapixel 1/1.8" W CMOS	8.4 Megapixel 1/1.8" W CMOS	4.1 Megapixel 1/1.7" W CMOS	8.4 Megapixel 1/1.8" W CMOS	4.5 Megapixel 1/1.7" W CMOS	4.1 Megapixel 1/2.9" CMOS	2.1 Megapixel 1/2" W CMOS
Lens*	Focal Length	5.6-272mm	5.8-510mm	6-218mm	5.6-272mm	6-180mm	6-218mm	4.7-141mm	6-218mm
	Optical Zoom	49X Optical Zoom + 16X Digital	88X Optical Zoom + 16X Digital	36X Optical Zoom + 16X Digital	49X Optical Zoom + 16X Digital	30X Optical Zoom + 16X Digital	36X Optical Zoom + 16X Digital	30X Optical Zoom + 16X Digital	36X Optical Zoom + 16X Digital
	Angle of View	75°-1.62° Horizontal	65°-0.86° Horizontal	65.2°-2° Horizontal	76.3°-1.7° Horizontal	65.2°-2.5° Horizontal	66.4°-2.1° Horizontal	67.9°-2.14° Horizontal	61.9°-1.89° Horizontal
	Focus	Auto / Manual	Auto / Manual	Auto/Manual	Auto / Manual	Auto / Manual	Auto/Manual	Auto/Manual	Auto/Manual
Minimum Illumination		Color: 0.05 Lux, B&W: 0.005 Lux @ f/1.4	Color: 0.05 Lux, B&W: 0.005 Lux @ f/1.4	Color: 0.1 Lux, B&W: 0.01 Lux @ f/1.5	Color: 0.005 Lux, B&W: 0.0005 Lux @ f/1.4	Color: 0.1 Lux, B&W: 0.01 Lux @ f/1.5	Color: 0.005 Lux, B&W: 0.0005 Lux @ f/1.5	Color: 0.005 Lux, B&W: 0.0005 Lux @ f/1.5	Color: 0.001 Lux, B&W: 0.0001 Lux @ f/1.5
Optical Fog Filter (NIR)		Yes	Yes	Yes	Yes	No	Yes	No	Yes
Heatwave Mitigation		No	Yes	No	No	No	No	No	No
NDAA Compliant		Yes	Optional	Yes	No	Yes	Yes	Yes	Optional
Video Network	Compression	H.265/H.264/MJPEG							
	Protocol	ONVIF, HTTP, RTSP, RTP, TCP, UDP							
Image Stabilization		Electronic Image Stabilization (EIS)							
Image Enhancements		Auto White Balance, 2D/3D DNR, BLC, HLC, Digital Defog							
Dynamic Range		WDR	WDR	WDR	100dB WDR	100dB WDR	WDR	WDR	100dB WDR
Edge Storage		Supports MicroSD Card up to 256GB							

*Lens measurements and angle of view are accurate to ±10% due to back focus distances, sensor sizes, lens manufacturing, etc.

ZLID™ Illumination Options

	150m IR	150m White	500m ZLID		750m ZLID		1000m ZLID		1500m ZLID		2000m ZLID	
Illumination Distance	150m	150m	500m		750m		1000m		1500m		2000m	
Wavelength	808nm	White Light	850nm	940nm	808nm	940nm	808nm	940nm	808nm	940nm	808nm	940nm
NOHD	0m (eye safe at any distance)		8.5m	6.9m	13m	9.6m	50m	36.6m	56.4m	45.2m	69m	51m

Thermal Camera Options

	19mm Fixed	25mm Fixed	35mm Fixed	55mm Fixed	75mm Fixed	26-75mm Zoom	15-235mm MWIR Zoom														
Image Sensor	Uncooled Vanadium Oxide (VOx) Microbolometer, 30Hz or 9Hz upon request						X-Hot Cooled Thermal, 30Hz														
Resolution	640×512/640×480 pixels (384×288 pixels optional)						640×480 or 640×512 pixels														
Pixel Pitch	12µm (Over 200% further range than 25µm sensors, 40% further range than 17µm sensors)						10µm														
Lens	19mm	25mm	35mm	55mm	75mm	26-75mm Zoom	15-235mm Zoom														
Focus	Athermalized	Athermalized	Athermalized	Motorized Focus	Motorized Focus	Motorized Autofocus	Motorized Autofocus														
Field of View on 640×512	22.9° Horizontal FOV	17.5° Horizontal FOV	12.5° Horizontal FOV	8.0° Horizontal FOV	5.9° Horizontal FOV	16.8°-5.9° Horizontal FOV	24.1-1.56° Horizontal FOV														
Human DRI Ratings*	752m	251m	125m	990m	330m	165m	1.3 km	462m	231m	2.6 km	871m	435m	2.9 km	990m	495m	2.9 km	990m	495m	11.1 km	3.7 km	1.8 km
Vehicle DRI Ratings*	1.7 km	581m	290m	2.3 km	764m	382m	3.2 km	1.0 km	535m	6.0 km	2.0 km	1.0 km	6.8 km	2.3 km	1.1m	6.8 km	2.3 km	1.1m	25 km	8.6 km	4.3 km
Image Optimizations	DICE (Dynamic Image Contrast Enhancement), BPR, NUC, & AGC user configurable via SDK, GUI						AGC, EIS, Denoise														
Digital Zoom	2X & 4X dynamic zoom/pan with range switching						4X Digital Zoom (16X Optional)														
Spectral Range	7,000-14,000nm (LWIR)						3,000-5,000nm (MWIR)														
Thermal Sensitivity	50mK						20-25mK														
Cooler Lifetime	No Cooler (maintenance free)						35,000 Hour Rated MTBF														
Image Display Modes	White Hot, other color palettes available upon request																				

* **D R I** DRI detection ratings are based on industry-wide standards (Johnson's Criteria) that can be misleading if not properly understood. For more information, please see our whitepaper about understanding DRI measurements at: www.infinitioptics.com/dri

Additional System Specifications

Optional LRF (Laser Rangefinder)**	LRF3	LRF4	LRF5	LRF12	LRF31	LRF38	LRF38-1M
Extended Range	3 km	4.6 km	5 km	12 km	31.5 km	38 km	38 km
Range to NATO Vehicle (2.3 × 2.3m)** Single Measurement / Continuous (10Hz)	1.7 km / 1.0 km	1.8 km / 1.2 km	2.5 km / 1.5 km	5.6 km / 3.7 km	12 km / 5 km	17 km / 7.2 km	17.5 km / 13.4 km
Precision	10-50 cm (depending on distance and target reflectivity)						

Pan/Tilt Mechanical

Pan Angle & Speed	Endless 360° Continuous Rotation, 00.1°/s to 97°/s, 0.01° minimum increment
Tilt Angle & Speed	-30° to +90°, 0.1°/s to 80°/s, 0.01° minimum increment
Proportional Pan/Tilt	Auto adjusts pan/tilt speed based on zoom level
Gyro Stabilization	2-axis, <0.2° RMS

Physical

Construction	High Strength Aluminum Alloy
Weight	30-36 lbs (13.6-16.3kg), depending on configuration
Wiper	Optional (must be specified in initial order)

Environmental

Operational Temperature	-30°C to +60°C, <90% Relative Humidity
Environmental	IP67 Weatherproof Housing

Electrical

Input Voltage	24VDC
Power Consumption	< 100W (will change depending on configuration)

Brochure specifications subject to change. **See our full LRF brochure for more information.

NEPTUNE
Dimensions

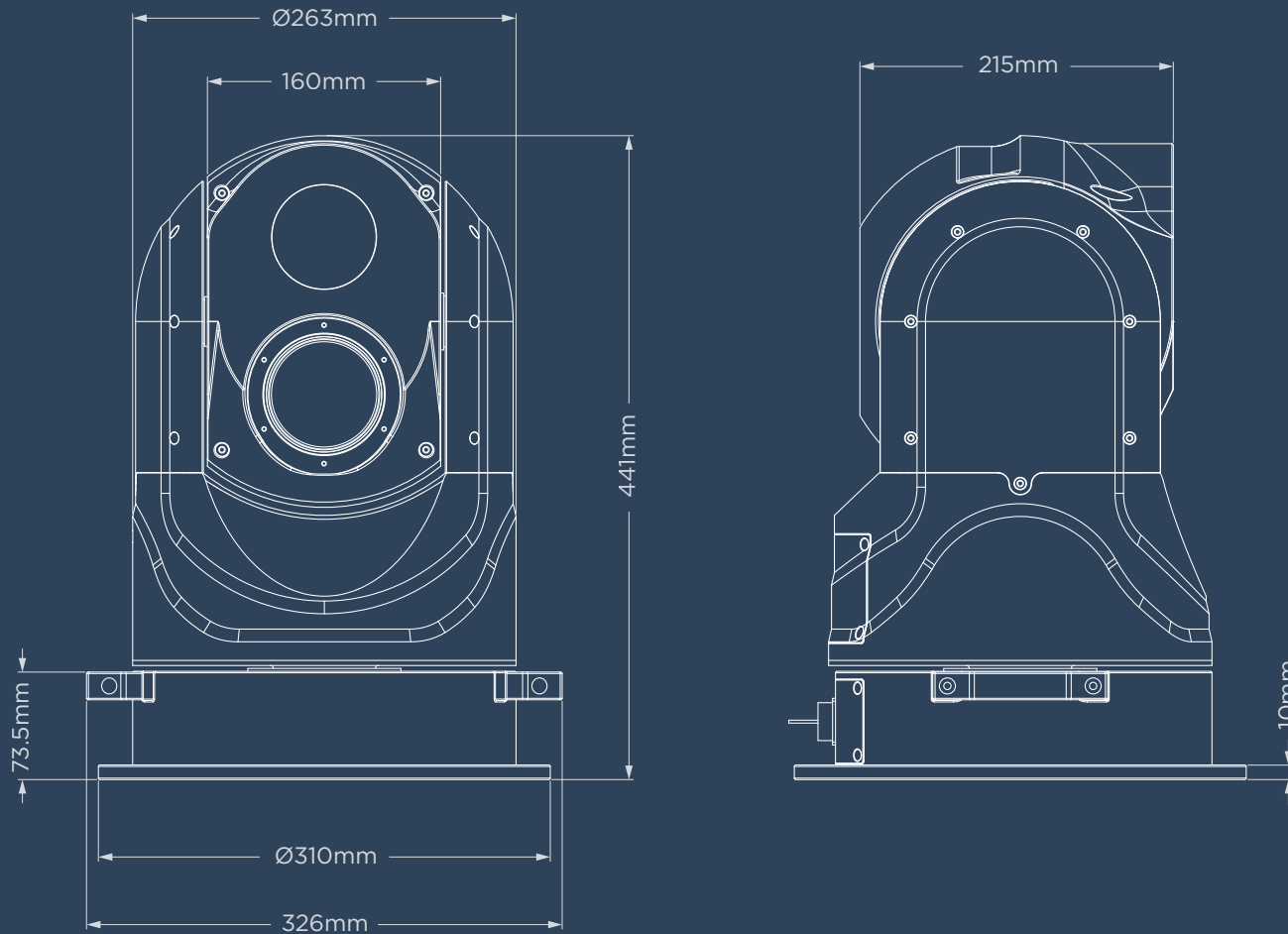

NEPTUNE

Additional Images



Examples of Neptune orders with custom RAL paint color and optional wiper (both must be specified at time of order).